

## NB TV S - Indirect heating within exchanger coil

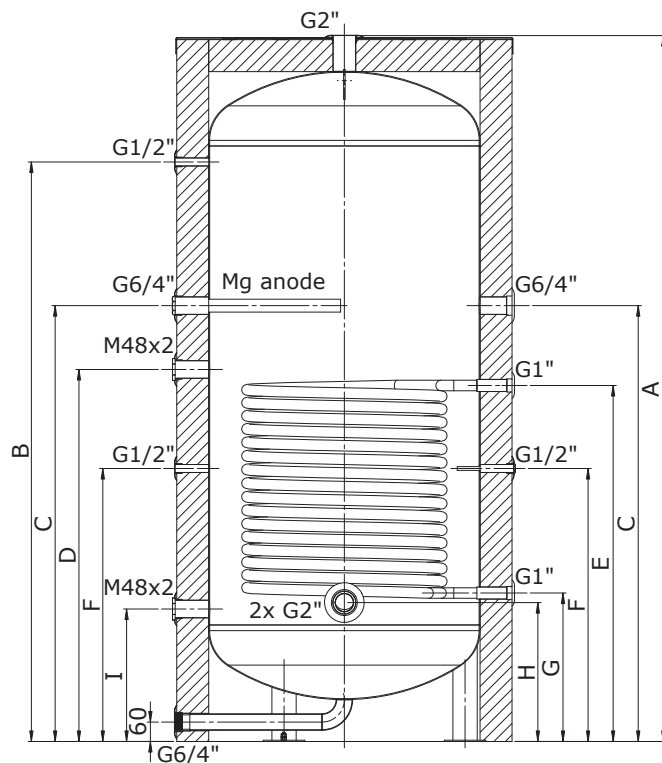

- For the preparation of DHW
- Indirect heating with exchanger using heat source (solid fuel boiler, gas boiler, solar system)
- High-quality insulation SYMBIO 100 mm is included
- An electric heating unit can be mounted into the M48x2 nozzle
- Magnesium anode protection is included

Model	NB TV 750 S	NB TV 850 S	NB TV 1000 S
<b>Material (tank/coil)</b>	AISI 316L / AISI 316L		
<b>Max. op. press. (tank/coil) [bar]</b>	10 / 10		
<b>Max. op. temp. (tank/coil) [°C]</b>	100 / 110		
<b>Heat transfer surface [m<sup>2</sup>]</b>	3.0	3.0	4.5
<b>Heating power [kW]*</b>	74	74	92
<b>Heating time [min]*</b>	29	34	33
<b>Insul. thickness / Nozzle lenght [mm]</b>	100 / 105		
<b>Temp. loss with insul. in 24 hours [°C]</b>	3	2.5	2.5
<b>Standing loss with insulation [W]</b>	96	108	121
<b>Warranty</b>	5 years		

\*Note: It was measured at a heating water temperature of 80 °C and a flow rate of 2.5 m<sup>3</sup>/h. This involves heating of DHW from 10 °C to 55 °C.

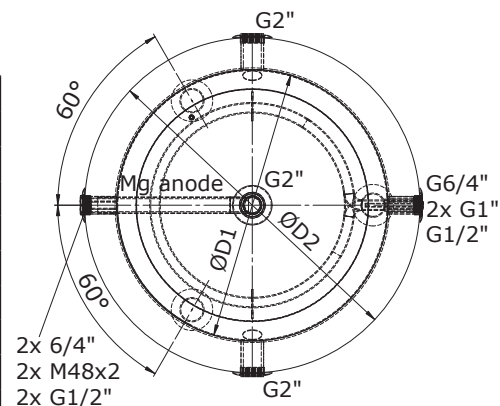

Model		NB TV 750 S	NB TV 850 S	NB TV 1000 S
<b>Order number</b>		<b>271075</b>	<b>271085</b>	<b>271100</b>
<b>Volume</b>	<b>V [L]</b>	704	825	998
<b>Diameter without ins.</b>	<b>ØD<sub>1</sub> [mm]</b>	790	790	850
<b>Diameter with ins.</b>	<b>ØD<sub>2</sub> [mm]</b>	990	990	1 050
<b>Total height</b>	<b>A [mm]</b>	1 840	2 090	2 210
	<b>B [mm]</b>	1 505	1 755	1 815
	<b>C [mm]</b>	1 155	1 155	1 365
	<b>D [mm]</b>	935	935	1 165
	<b>E [mm]</b>	885	885	1 115
	<b>F [mm]</b>	725	725	855
	<b>G [mm]</b>	405	405	465
	<b>H [mm]</b>	375	375	435
	<b>I [mm]</b>	355	355	415
<b>Net weight incl. ins.</b>	<b>m [kg]</b>	139	153	173